

Fact Sheet

EvoFlat MSS fully insulated

Flat station for single - family, semi - detached and terraced houses as well as flats



FEATURES AND BENEFITS

- Flat station for decentralized heating systems
- Direct heating, DHW heating based on flow principle with thermostatic temperature controller
- Innovative, energy-saving controller TCP - M in combination with high performance heat exchanger for ondemand water heating without no-load losses
- Capacity: 15 kW HE, 55 kW DHW
- Minimum space required for installation
- Built-in or wall-mounted variant
- Pipes and plate heat exchanger made of stainless steel
- Plate heat exchanger in copper brazed or gasketed version
- Minimized risk of lime scale and bacteria formation

Application

The EvoFlat is a compact and simple to operate flat station. The EvoFlat is especially suitable for two-pipe systems in residential buildings, which are supplied from a secondary connected district heating system, a block heating system or a centrally located boiler system. The EvoFlat is available as built-in variant with a recess box or as mount-on-wall variant.

Primary side (HS)

The flat station is prefabricated with interconnecting components such as a differential pressure controller (integrated in main temperature controller TPC-M), strainer, sensor pockets and fitting piece for insertion of a heat meter. Thermostatic bypass is available as an option.

Heating (HE)

The self-acting temperature controller TPC-M with integrated differential pressure controller sets the optimum operating conditions for heating and DHW. The mixing loop creates a suit-

able temperature level e.g. for floor heating. In order to enable a time dependent temperature control program, a zone valve with actuator and a room thermostat can be included as an option.

Domestic hot water (DHW)

The domestic hot water is prepared in the heat exchanger based on the flow principle and the temperature is regulated by the self-acting controller with integrated differential pressure controller - the TPC-M. Supreme ease of operation is obtained via the combined hydraulic and thermostatic regulation of the TPC-M controller. The flow - controlled part allows primary and secondary side flow through the heat exchanger, only when hot water is tapped and blocks the flow immediately after completion of the tapping process. The thermostatic part controls the domestic hot water temperature. Thanks to the quick-acting hydraulic control of the heat exchanger, it is largely protected from the

formation of lime scale and growth of bacteria. The TPC-M controller with integrated differential pressure controller compensates for variations in supply temperature and varying differential pressure and thereby ensures a constant domestic hot water temperature at all times. For registration of the cold water consumption the EvoFlat is equipped with a fitting piece for mounting of a cold water meter in the DCW inlet.

Construction

All pipes are made of stainless steel. The connections are made by a newly designed click connection, which does not need retightening.

Insulation

The EvoFlat is built up on an EPP insulation back plate and a front insulation cabinet is available as an option, enabling the customer to have a fully insulated substation, thus ensuring reduced heat losses and excellent operating economy.

CIRCUIT DIAGRAM – EXAMPLE

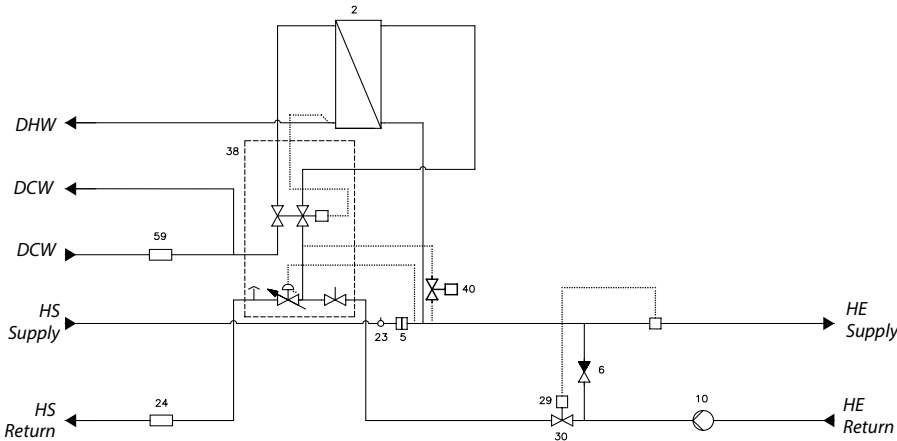

- 2 Plate heat exchanger Danfoss XB06H -1
- 5 Strainer 3/4" N/N mv=0,6 mm
- 6 Non-return valve
- 10 Circ. pump HE Wilo Yonos Para
- 23 Sensor pocket 1/2"
- 24 Fitting piece for energy meter 3/4" x 110 mm
- 29 Temp. sensor
- 30 Temp. controller
- 38 Hot Water Controller TPC - M
- 40 By-pass/circulation Danfoss FJVR (optional)
- 59 Fitting piece for water meter 3/4" x 110 mm

Design specifications:

Nominal pressure (prim/sec.): PN 6 / PN 10
 Max. supply temperature: 95 °C
 DCW static pressure: P_{min} = 1,5 bar
 Brazing material (HEX): Copper

Weight excl. cover:

14 kg
 19 kg**

Insulation:

EPP λ 0,039

Cover:

White-lacquered steel

Electrical supply:

230 V AC

Dimensions (mm):

With connections:
 H 590 × W 550 × D 150*
 * Depth incl. mounting plate
 H 590 × W 590 × D 150**
 ** In gasketed versions

Connections sizes:

DH, HE, DHW, DCW:
 G 3/4" (int. thread)
 space 65 mm

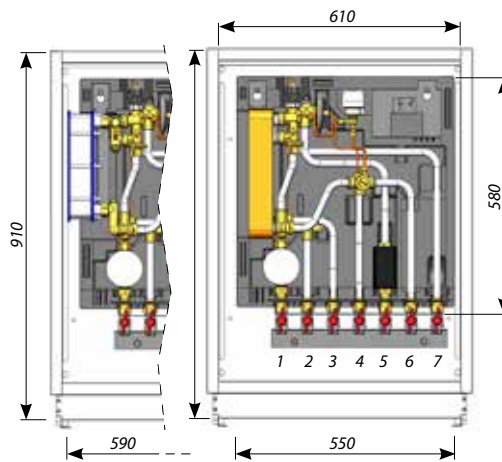

Connections:

1. Domestic cold water (DCW) inlet
2. Domestic hot water (DHW) outlet
3. Domestic cold water (DCW) outlet
4. Primary side (HS) supply
5. Primary side (HS) return
6. Heating (HE) supply
7. Heating (HE) return

Options:

- Room thermostat
- Actuator for zone valve
- Ball valves (60 mm)
- Ball valves with connection for pressure gauge 3/4" (120 mm) incl. safety valve
- Mounting rail for wall mounted variant
- Recess box for built-in variant incl. mounting rail
- Bypass
- Isolated front cover
- DHW circulation
- Gasketed plate heat exchanger

DHW: CAPACITY EXAMPLES

DHW capacity [kW]	Type	Temperature primary [°C]	Temperature secondary [°C]	Flow rate primary [l/h]	Flow rate secondary [l/h]	Pressure loss primary [*kpa]
37	1	65/19,1	10/45	707	910	16
37	1	65/22,4	10/50	762	796	18
45	2	65/17,6	10/45	833	1106	18
45,5	2	65/20,6	10/50	890	968	21
55,5	3	65/14	10/45	950	1365	41
53	3	65/15,8	10/50	950	1140	41
42	3	55/16,3	10/45	950	1033	41
33,7	3	50/19,1	10/45	950	829	41
37	G1	65/25	10/45	850	910	25
37	G1	60/28	10/50	865	796	30

* Energy meter not incl.

HEATING: CAPACITY EXAMPLES

Heating capacity	Heating circuit Δt [°C]	Total pressure loss primary [*kpa]	Flow rate primary [l/h]
10	20	9	430
10	30	3,5	287
10	40	2	215
15	20	30	645
15	30	9	430
15	40	5	323

* Energy meter not incl.

Type 1 = XB 06H-1 26 (plate heat exchanger)
 Type 2 = XB 06H-1 40 (plate heat exchanger)
 Type 3 = XB 06H+ 60 (plate heat exchanger)

Danfoss Redan A/S · District Heating · Omega 7, Søften · DK-8382 Hinnerup · Denmark
 Tel.: +45 87 43 89 43 · Fax: +45 87 43 89 44 · redan@danfoss.com · www.redan.danfoss.dk

Danfoss can accept no responsibility for possible errors in catalogues, brochures and other printed material. Danfoss reserves the right to alter its products without notice. This also applies to products already on order provided that such alterations can be made without consequential changes being necessary in specifications already agreed. All trademarks in this material are property of the respective companies. Danfoss and the Danfoss logotype are trademarks of Danfoss A/S. All rights reserved.